

USABLE DIAMETER RANGE: 0.005" - 0.035"

MIN THRU HOLE: 0.045"

JAW MATERIAL: 440C MIN 55Rc

GRIPPING LENGTH OF JAWS: 0.250"

.XX ±.010
.XXX ±.005
.XXXX ±.001

mat'l:

finish:

Blockwise Engineering LLC
113 S, 25th St.
Phoenix, AZ 85034
602-954-7703

MICROCHUCK
MODEL MCB

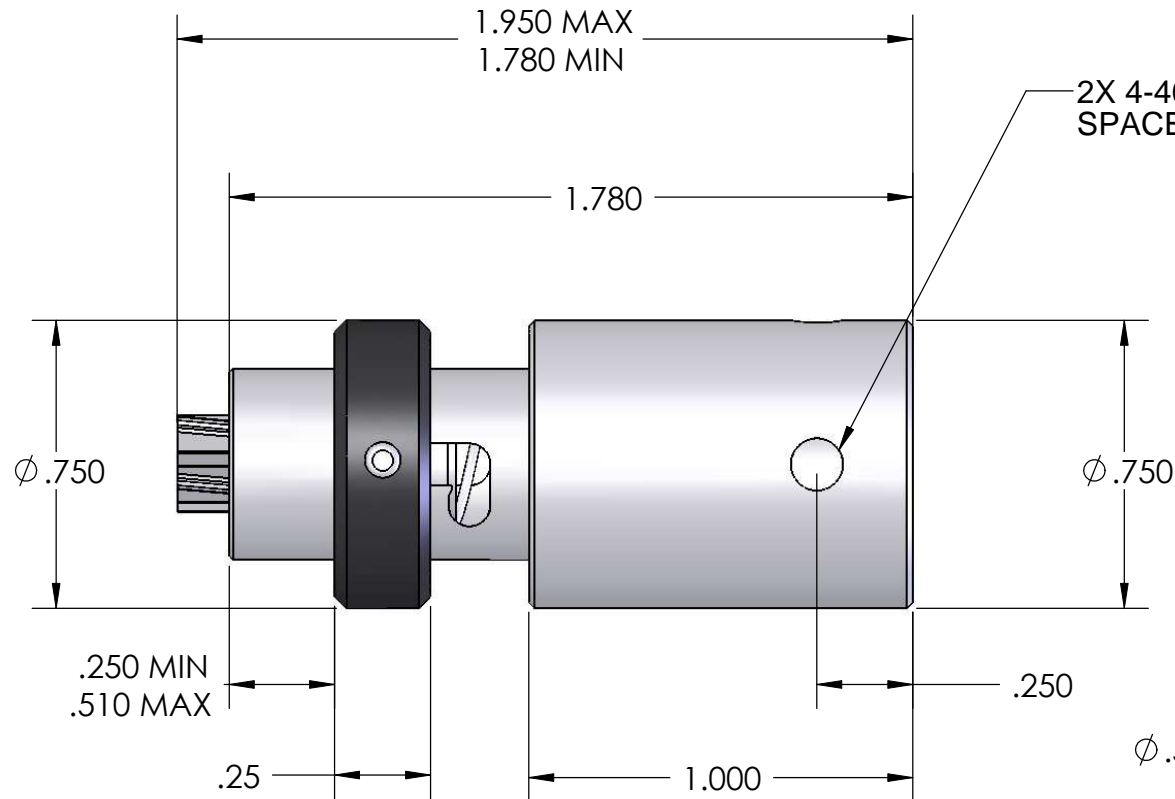
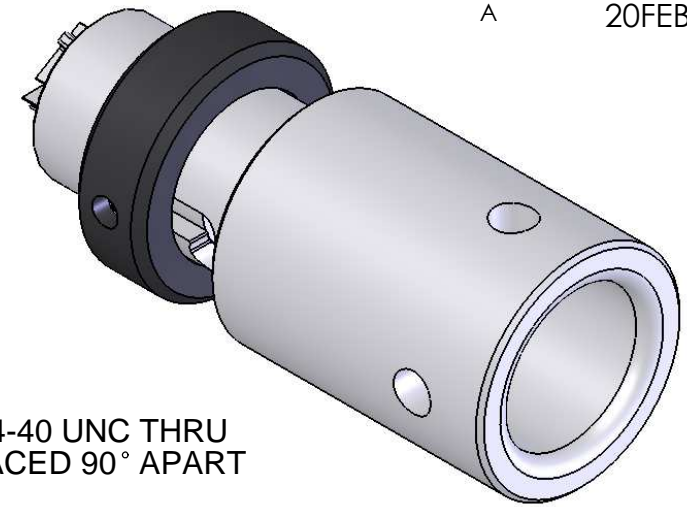

2X 4-40 UNC THRU
SPACED 90° APART

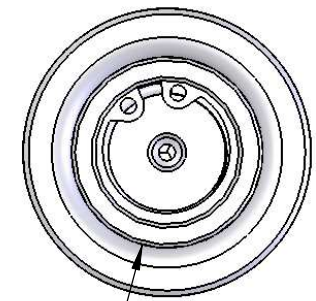

$\phi .5001^{+.0004}_{-.0000}$ $\phi .500$

USABLE DIAMETER RANGE: 0.005" - 0.035"

MIN THRU HOLE: 0.045"

JAW MATERIAL: 440C MIN 55Rc

GRIPPING LENGTH OF JAWS: 0.250"

Blockwise Engineering LLC
113 S. 25th St.
Phoenix, AZ 85034
602-954-7703

MICROCHUCK
MODEL MCB WITH .5" ADAPTER